

FLEXA®

82-40011-40

153 x 39.5 x 120cm

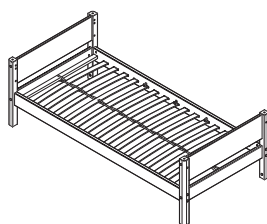
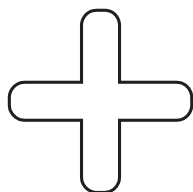

80-17101-40/-95
80-17102-40/-95

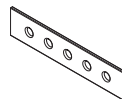

80-17607-40/-42/-44
80-17608-40/-42/-44

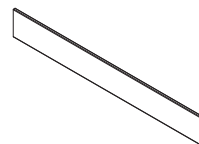

80-17603-40
80-17603-40

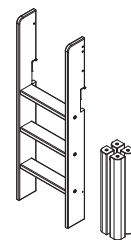

80-17305-40

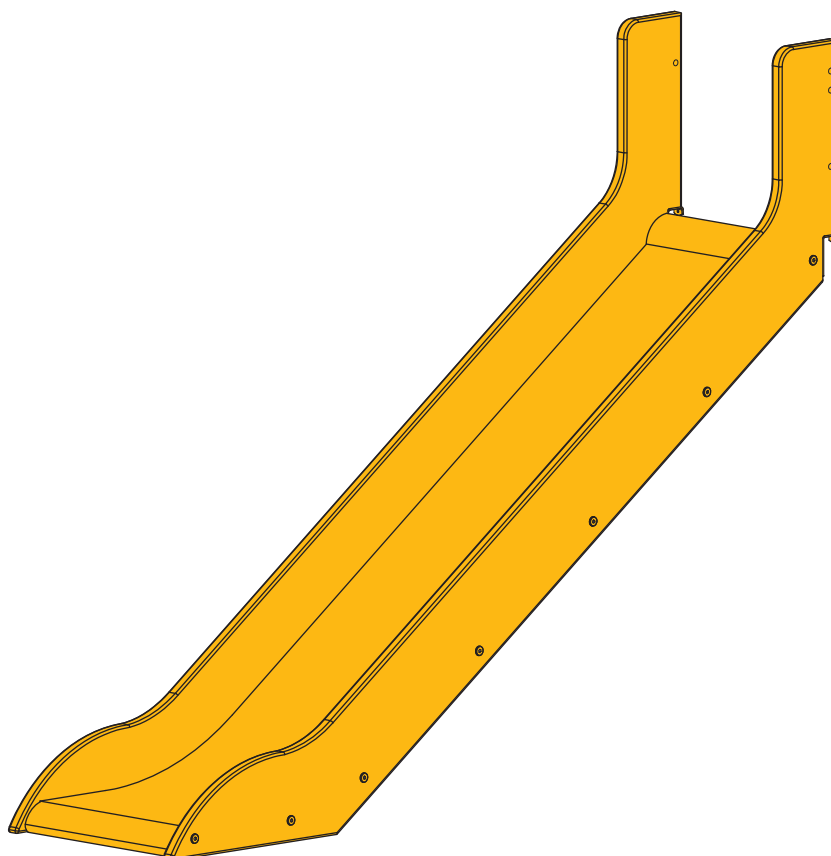

For indoor
domestic use



Danish Design made in Estonia

Monterings- og brugsvejledning

Assembly instructions and
directions for use

Montageanleitung und
Gebrauchsanweisung

Notice de montage et mode
d'emploi

Instrucciones de montaje y uso

Montageinstructie en onderhouds
voorschrift

Istruzioni di montaggio e uso

2/April 2012
44-01235



Møbler fra FLEXA er fremstillet af enten massivt træ eller højkvalitets MDF.

Massivt træ kan have farve- og strukturforskelle, hvilket er en naturlig del af møblet, fordi det er et naturmateriale.

Skulle der mod forventning opstå en reklamation, skal denne blanket udfyldes og returneres til FLEXA forhandleren. Venligst kontroller, at alle dele er komplette, inden montage påbegyndes.



Furniture from FLEXA is produced from solid wood or high quality MDF.

Solid wood can have color and structure difference which is a natural part of the furniture.

However should a complaint occur, this form must be filled and returned to your FLEXA stockist. Please make sure that all parts are complete before you start assembling.



Die FLEXA Produkte werden aus massivem Kiefernholz oder aus MDF von hoher Qualität hergestellt.

Bei massivem Holz sind Farbunterschiede sowie unterschiedliche Maserungen Naturmerkmale.

Sollte es trotzdem Grund zur Reklamation geben, füllen Sie bitte diesen Schein aus und wenden Sie sich an Ihren FLEXA Händler. Kontrollieren Sie vor Montagebeginn den Artikel auf Vollständigkeit und Beschädigungen.

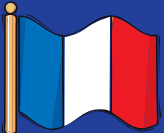

Le mobilier FLEXA est réalisé en bois massif ou en MDF de haute qualité.

La structure et la couleur du bois massif peuvent différer car c'est une matière naturelle.

Si toutefois vous constatez une anomalie, merci de remplir la fiche ci-jointe et de la retourner à votre revendeur. Veuillez vérifier l'intégralité des pièces avant d'entreprendre le montage.



Los muebles de FLEXA son fabricados con madera maciza o MDF de alta calidad.

La madera maciza puede tener diferencias de color y de estructura, esto es una parte natural de los muebles.

Si en contra de lo previsto surge una incidencia, hay que rellenar este formulario y devolverlo al distribuidor. Les rogamos controlen que todas las piezas están completas antes de empezar el montaje.



Meubels van FLEXA zijn geproduceerd van massief hout of hoge kwaliteit MDF.

Bij massief hout kunnen kleur- en structuurverschillen voorkomen, wat een natuurlijk kenmerk is van het meubel.

Mocht er desondanks een klacht ontstaan, vul dan dit formulier in en lever het in bij uw FLEXA dealer. Controleer of alle benodigde onderdelen aanwezig zijn voordat u begint met monteren.

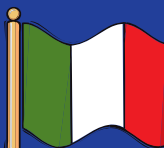

I mobili FLEXA sono prodotti in legno massello o MDF di alta qualità.

Il legno massiccio può avere alcune differenze di colore o di consistenza, il che è normale per un materiale naturale.

Comunque per qualsiasi reclamo bisogna riempire il modulo e consegnarlo al Vostro rivenditore. Vi preghiamo di controllare che tutti i pezzi siano intatti prima di cominciare il montaggio.



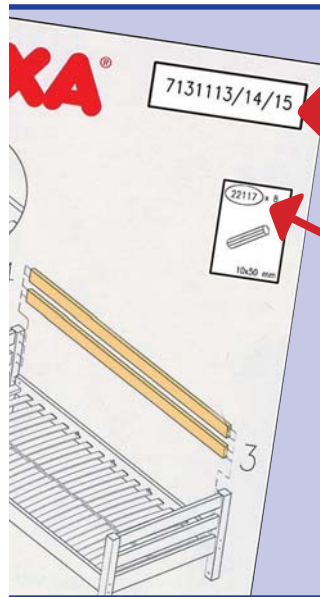

Model nr. / Model No / Modell Nr. /
Modèle no / No Modelo / Artikel nr. /
Numero Modello

Emne nr. / Part / Teile-Nr. /
Pièce réclamée / No. pieza /
Onderdeelnummer / No. pezzo

Årsag

1

Manglende del / Missing part/
Fehlendes Teil / Pièce manquante /
Falta pieza / Missende delen / Parte
mancante

Reason

Ursache

2

Motif

Motivo

Oorzaak

Motivo

Fejl i træet / Defect in the wood /
Holzfehler / Défaut de bois /
Madera defectuosa / Fout in het
hout / Difetto nel legno

Fejlboring / Faulty drilling
Falsche Bohrung / Défaut de
perçage
Taladro erróneo / Verkeerd geboord
Difetto forature

4

Fejl i lakken / Fault in lacquer
Fehler im Lack / Défaut de finition
Barniz defecto / Fout in de
lakafwerking / Difetto laccatura



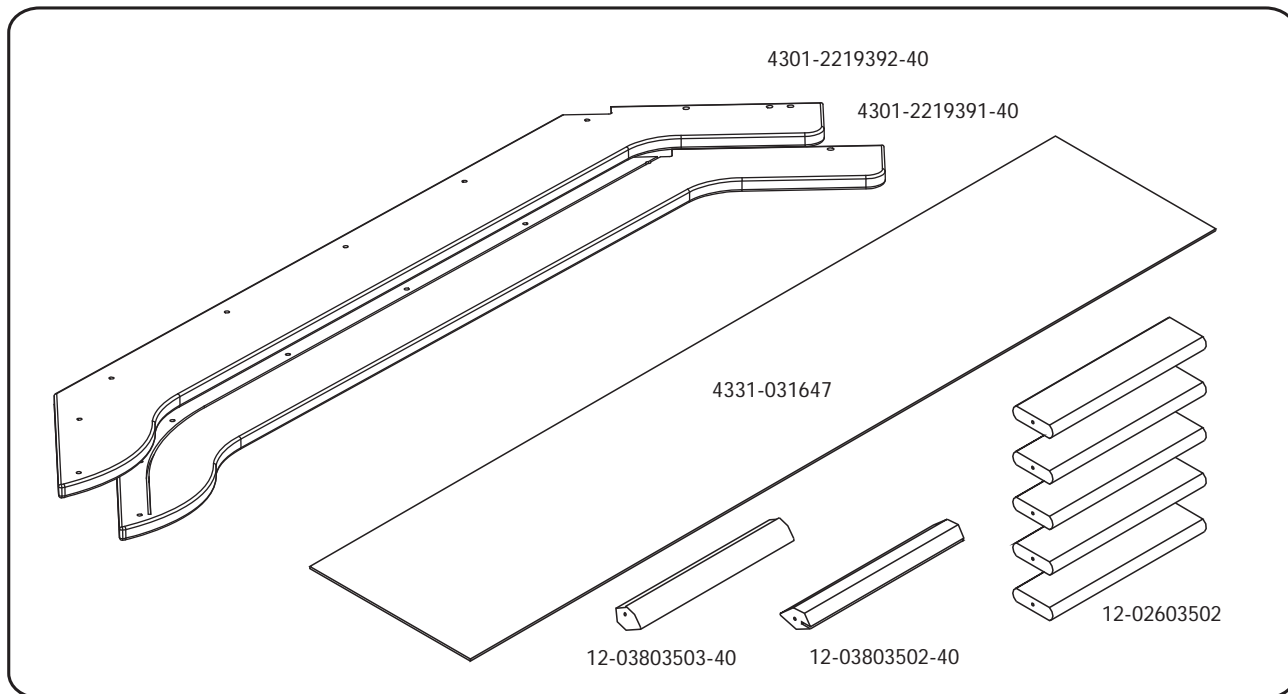
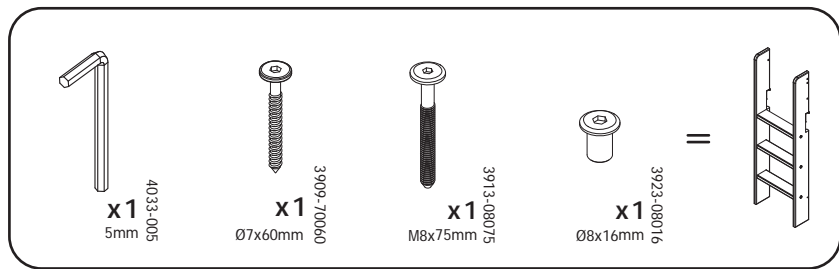
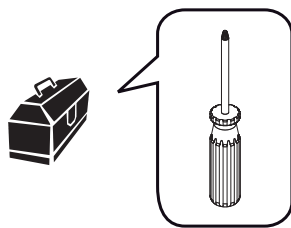
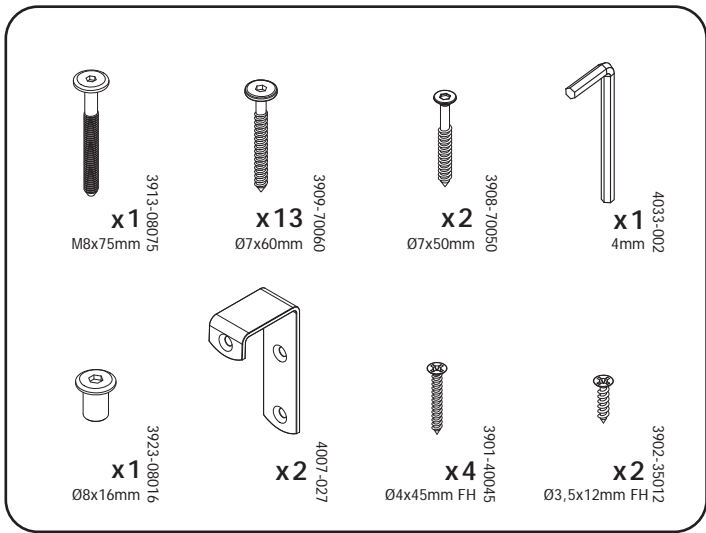

1

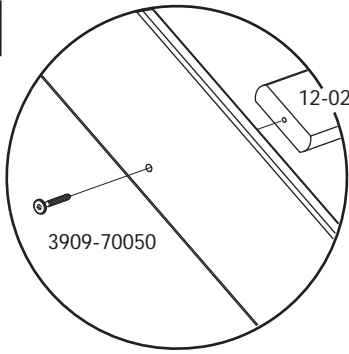

4301-2219392-40

4301-2219391-40

12-02603502

12-02603502

12-03803503-40

12-03803502-1/-2

3

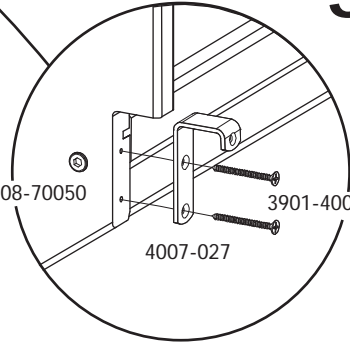

2

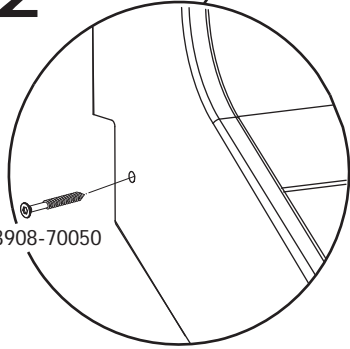

4331-031647

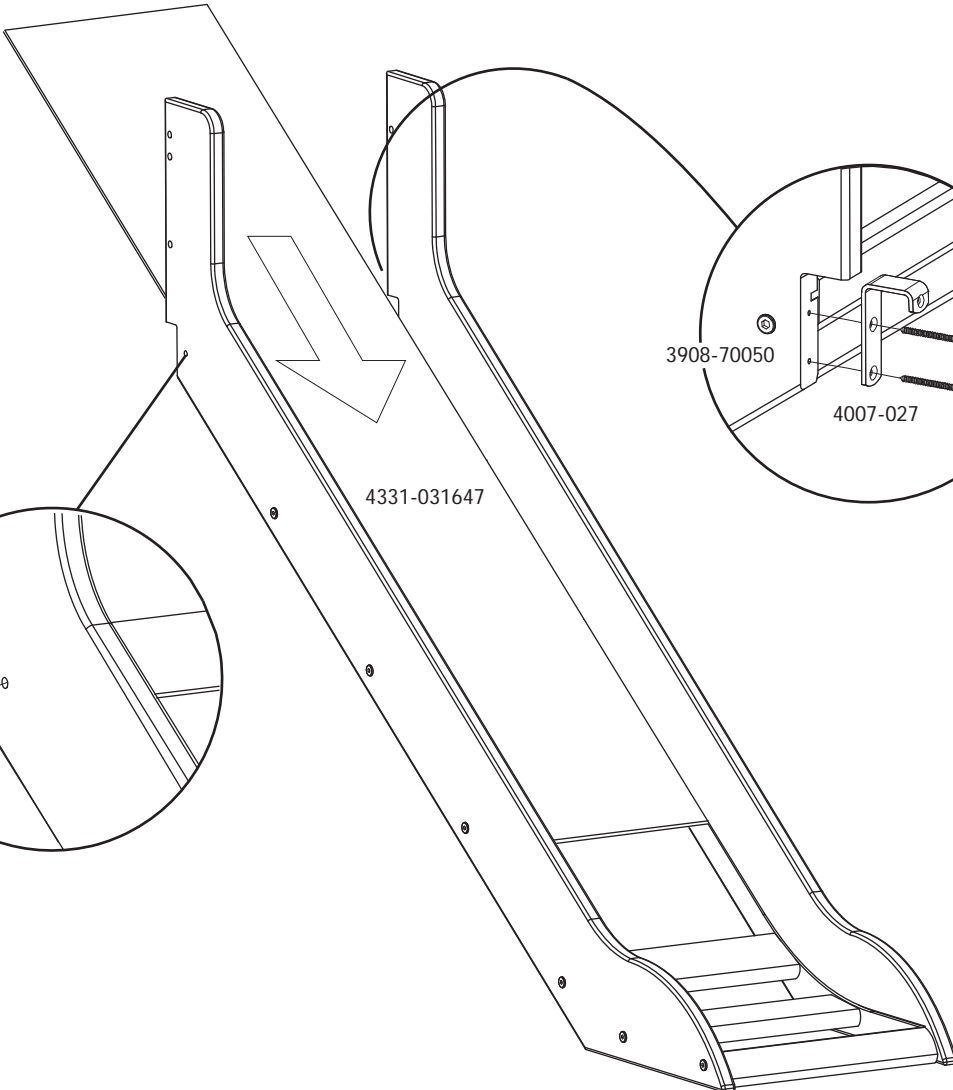

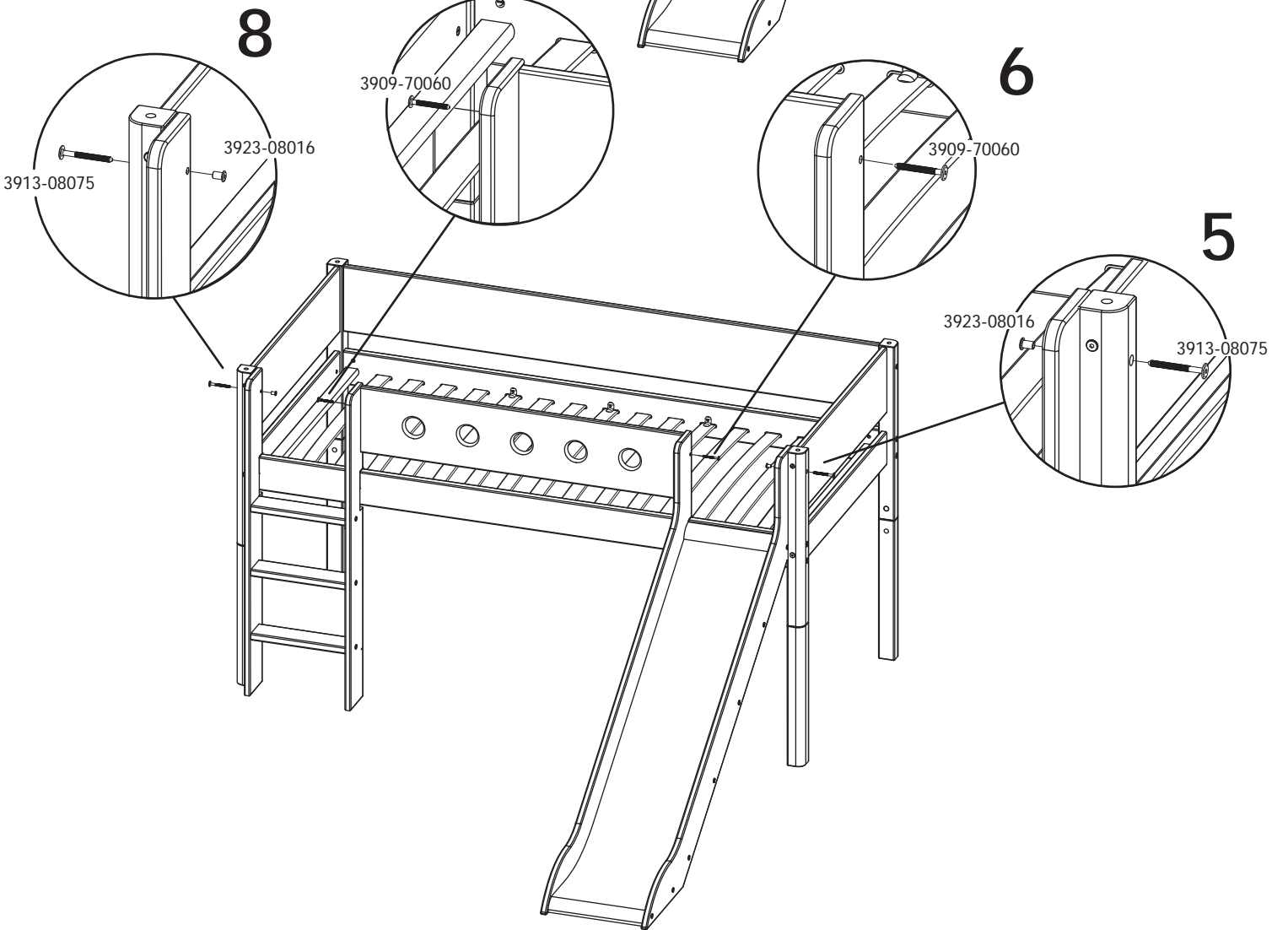
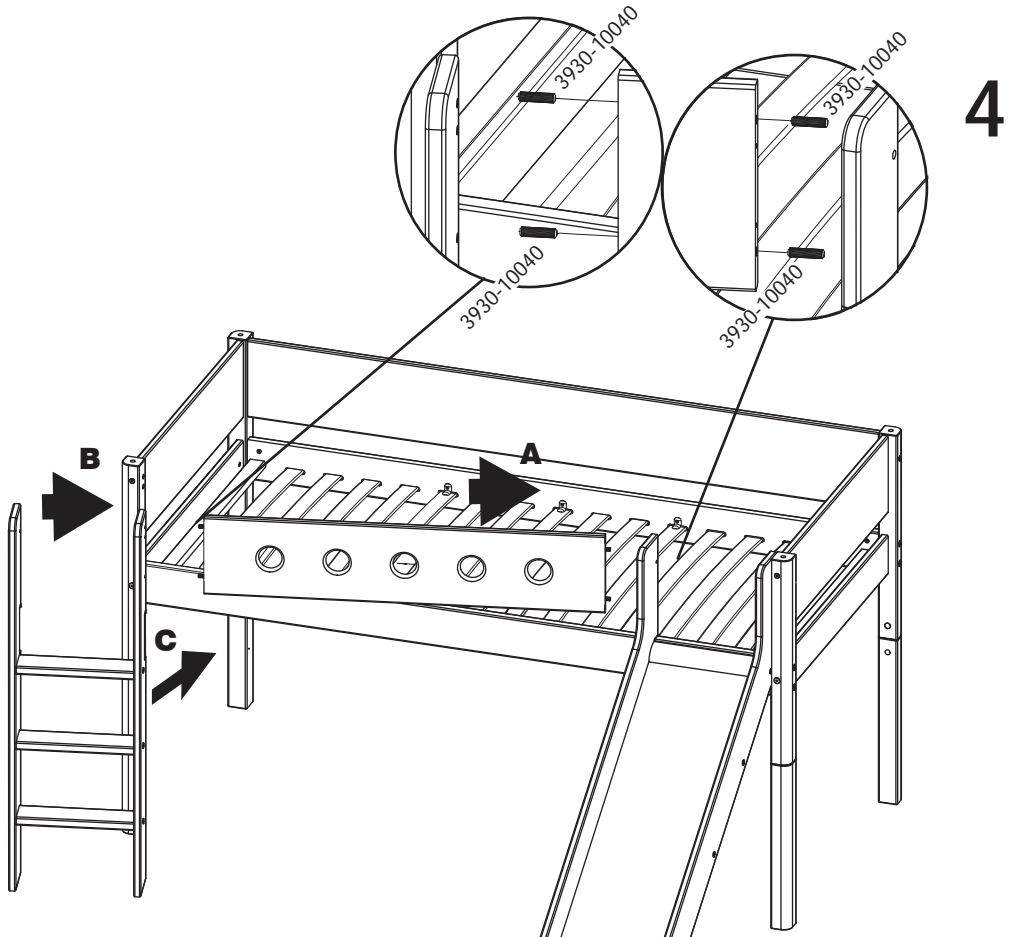

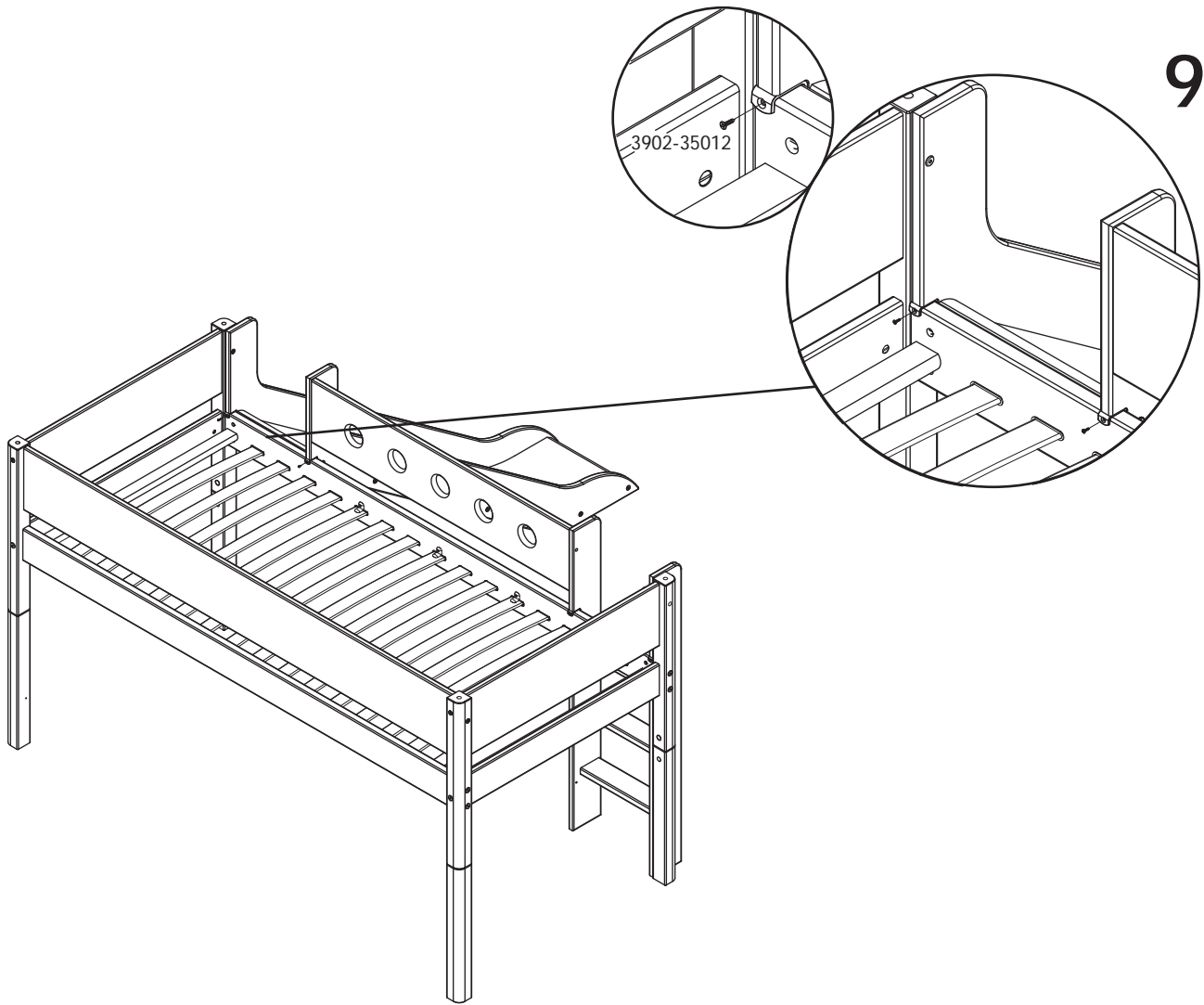

9

ADVARSEL: Vær opmærksom på, at der skal være tilstrækkelig med fri plads til barnets hovede og glideflade.

Det anbefales, at børn under 3 år kun benytter rutschebanen under opsyn af voksne.

RÅD OM VEDLIGEHOLDELSE:

Tør af med en fugtig klud. Evt. større pletter fjernes med en fugtig svamp med sæbe. Undgå opløsningsmidler.

Skruer og bolte bør efterspændes med jævne mellemrum.

WARNING: Make sure that there is sufficient free space for the child's head and sliding surface.

It is recommended that children under 3 years of age are under supervision by adults when using the slide.

MAINTENANCE INSTRUCTIONS: Cleaning with a wet cloth, use a sponge with soap to remove obstinate dirt.

Avoid solvents and dilutions.

Screws and bolts should from time to time be retightened.

WARNUNG: Beachten Sie den erforderlichen Freiraum um die Rutsche für den Kopf und die Gliedmasse des Kindes.

Es wird empfohlen dass Kinder unter 3 Jahren die Rutsche unter Aufsicht von Erwachsenen.

PFLEGEHINWEIS: Pflege mit einem feuchten Lappen.

Für hartknäckigen Schmutz empfehlen wir einen Schwamm mit Seife. Vermeiden ermeiden Verdünnungsmittel.

Schrauben und Bolzen sollten regelmässig nachgezogen werden.

Presta gran atención de que hay espacio suficiente para la cabeza del niño y del espacio para trencor.

Se recomienda, que niños menores de 3 años solo usen el tobogán bajo supervisión de un adulto.

CONSEJO PARA LA CONSERVACIÓN Limpiar con un paño húmedo.

Para quitar manchas mas grandes usar productos quimicos.

Los herrajes necesitan apretarse a veces.

AVERTISSEMENT: Être attentif à la place libre nécessaire pour le dos et la tête de l'enfant.

Il est recommandé de laisser les enfants de moins de 3 ans utiliser le toboggan sous surveillance d'un adulte.

F

CONSEILS D'ENTRETIEN: Entretenir avec un chiffon humide pour la poussière - les tâches rebelles s'enlèvent avec une éponge légèrement savonneuse.

Eviter tous solvants et diuants.

Votre toboggan doit être vérifié périodiquement afin de resserrer les vis.

WAARSCHUWING: Zorg voor voldoende ruimte rondom de glijbaan voor het hoofd en het lichaam van het kind.

Het is aan te bevelen dat kinderen onder de 3 jaar de glijbaan gebruiken onder toezicht van een volwassene.

NL

ONDERHOUD: Reinigen met een vochtige doek. Hardnekkig vuil verwijderen met een spons en zeep. Vermijd oplossen verdunningsmiddelen. Schoeven en moeren regelmatig aanraaien.

AVERTENZA: Siate attenti che ci sia abbastanza spazio libero per la sciana e la testa del bambino.

Si consiglia, che bambini al di sotto dei tre anni siano sotto sorveglianza degli adulti quando utilizzano lo scivolo.

I

CONSIGLI PER LA MANUTENZIONE: Pulire con un panno umido, usare una spugna impregnata di sapone per togliere lo sporco persistente. Evitare l'uso di prodotti chimici.

Dadi e viti sono, di tanto e tanto, da ri-avvitare.